

SCHNITT A-A

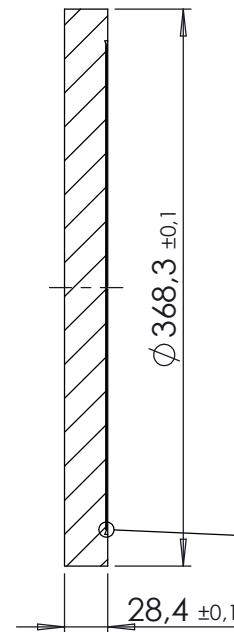

DETAIL X
MAßSTAB 4 : 1

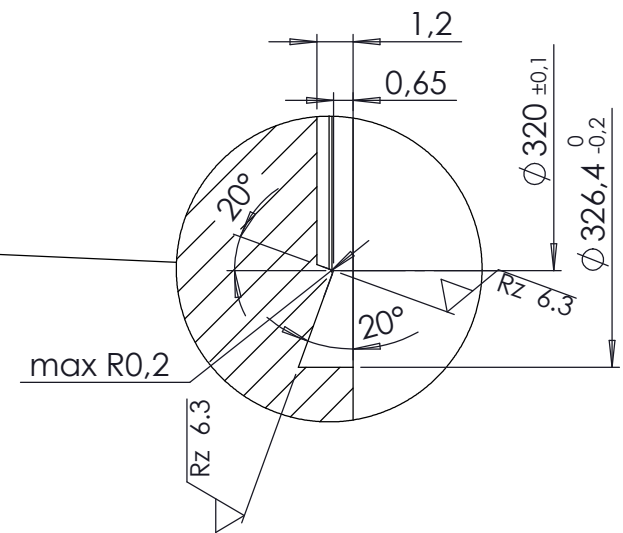

Bemerkungen (Remarks)				Freimaßtoleranz (Standard Tolerance)		Maßstab (Scale)		Rauheit (Roughness)		europ.Projektion	
All informations provided in this drawing is considered to be confidential, proprietary and secret information. It is intended only for the use of individual or entity to whom it is sent. Individual or entity agrees to not disseminate or copy this information to anyone other than originally specified without the written consent Allectra GmbH.				DIN ISO 2768 f-H		1:5		$\sqrt{Rz 16 (Rz 6.3)}$			
				Material, Standard		1.4404 (316L)		Kanten (edges)			
				Datum		Name		Bezeichnung (Title)		Gewicht (weight)	
				Design 18.08.2022		JB		blank fix flange DN300 CF		g	
				Drawn 19.08.2022		JB				22734.49	
				Check				Page:		Pages:	
								1		1	
						Zeichnungsnummer (Drawing No.)		411-CFB300		Revision	
Index						Modification		Date		Name	
								Datei (File)		c:\PDM2017C:\PDM2017\	