

POS. NO.	DESCRIPTION	MATERIAL	QTY
1	modified flange DN16 CF	1.4404 (316L)	1
2	SMP feedthrough, double sided, limited detent	1.4306 (304L)	4

SECTION A-A

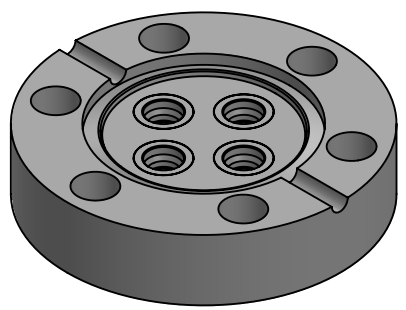
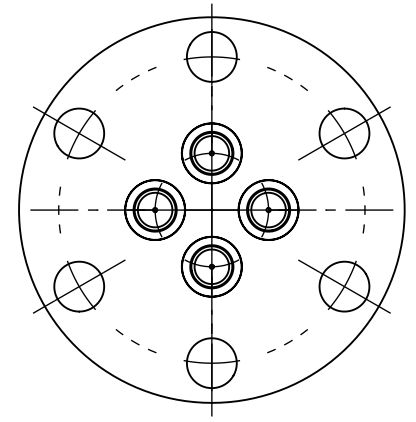
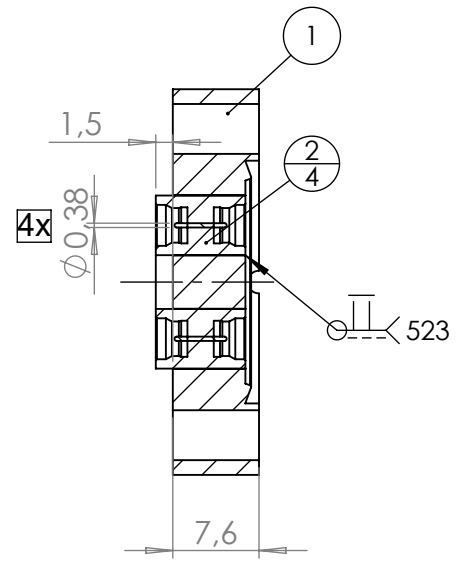
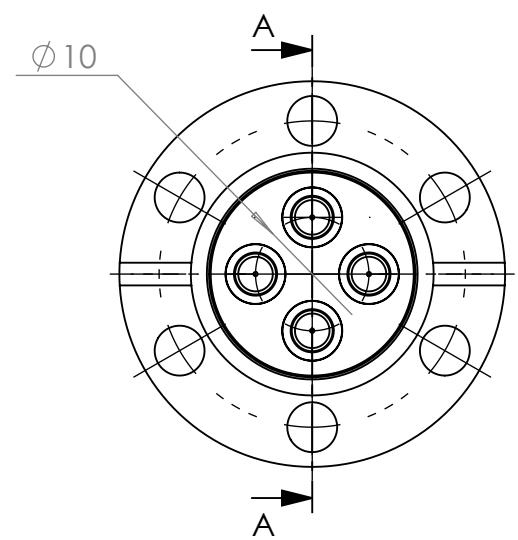

<1 E-10 mbar*/sec, He, according to DIN EN 1779-A3
Definition Leckprüfung (definon leak check)

Zeichnung Nutzung (SCOPE OF DRAWING) Drawing external usage for customer		Prüfung Zubehör. (CON + HSG CHECK)		Bemerkung (REMARKS)		Kanten (EDGES)		PROJECTION	
All informations provided in this drawing is considered to be confidential, proprietary and secret information. It is intended only for the use of individual or entity to whom it is sent. Individual or entity agrees to not disseminate or copy this information to anyone other than originally specified without the written consent Alletra GmbH.		Werkstoff (MATERIAL):		Gewicht (WEIGHT):		Toleranz (TOLERANCE):			
		Oberfläche (SURFACE):		Maßstab (SCALE):		Format. (FORM)			
		Cleaned UHV- Compatible		1.5:1		A4		1	
name		Alletra standard		DATE		NAME		Benennung (DESCRIPTION): 4 off SMPD f/t, double sided, limited detent on flange DN16 CF	
(drw/doc/sketch)				Design		AD			
date				Drawn		AD			
				Check		JB			
00		first origin		Approv		AD		REV	
						Zeich. Nr. (Drw. No.):		REV	
						242-SMPD-LD-C16-4		00	
REV		Beschreibung (CHANGING)		gesp. am (SAVE DAT.):		12.09.2024		Art. Nr. (PART NO.) 242-SMPD-LD-C16-4	