

44 pins D=0,7mm

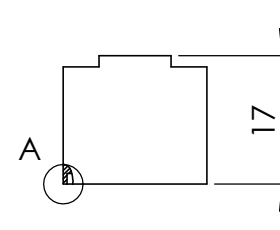

DETAIL A
MAßSTAB 2 : 1

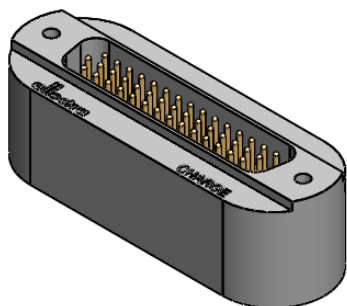
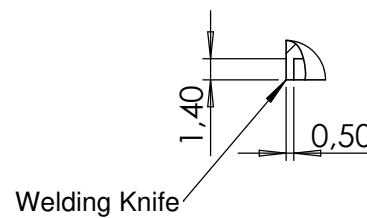

Bemerkungen (Remarks)				Freimaßtoleranz (Standard Toleranz)		Maßstab (Scale)	Rauheit (Roughness)		europ.Projektion		
All informations provided in this drawing is considered to be confidential, proprietary and secret information. If is intended only for the use of individual or entity to whom it is sent. Individual or entity agrees to not disseminate or copy this information to anyone other than originally specified without the written consent Allectra GmbH.						1:1					
											Material, Standard
							Oberfläche (Treatment)		Kanten (edges)		
							Bezeichnung (Title)		Gewicht (weight)		
		Datum	Name	44 pin SUB-High Density f/t				g			
		Design	09.03.2015	FW	weldable				82.54		
		Drawn	10.09.2019	AD					Page: 3 Pages: 6		
		Check							Revision		
						Zeichnungsnummer (Drawing No.) 218-HD44-SS					
Index	Modification	Datum	Name			Datei (File) C:\PDMStore\C\PDMStore\				Format A4	