

2 x Ø 2,26 ± 0,05
4-40 UNC ± 0,35

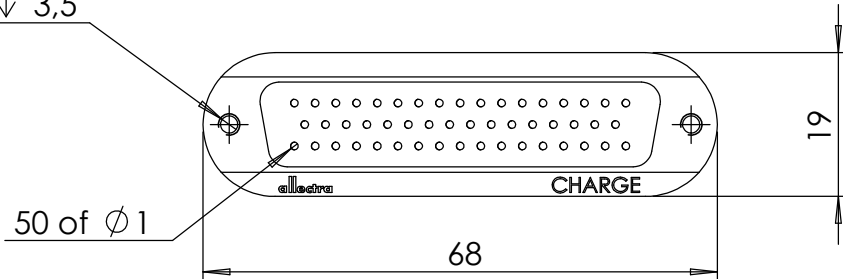

DETAIL A
MAßSTAB 2 : 1

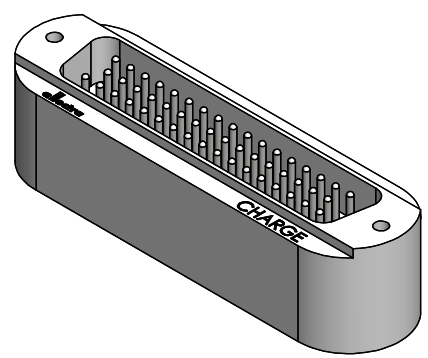
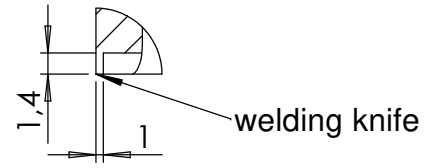

Bemerkungen (Remarks)				Freimaßtoleranz (Standard Toleranz)		Maßstab (Scale)	Rauheit (Roughness)		europ.Projektion	
All informations provided in this drawing is considered to be confidential, proprietary and secret information. If is intended only for the use of individual or entity to whom it is sent. Individual or entity agrees to not disseminate or copy this information to anyone other than originally specified without the written consent Allectra GmbH.						1:1	Material, Standard Oberfläche (Treatment)		Kanten (edges)	
				Datum						
				Design			94.96			
				Drawn			94.96			
				Name		Bezeichnung (Title)		Page: Pages:		
				Date		50 pin SUB-D f/t Titanium weldable type		1 1		
				Check						
Index				Modification		Datum		Name		
								Revision		
								Format A4		



Zeichnungsnummer (Drawing No.)
218-D50-TI

Datei (File) C:\PDMStore\C\PDMStore\