

2 x 4-40 UNC ∇ 3,5

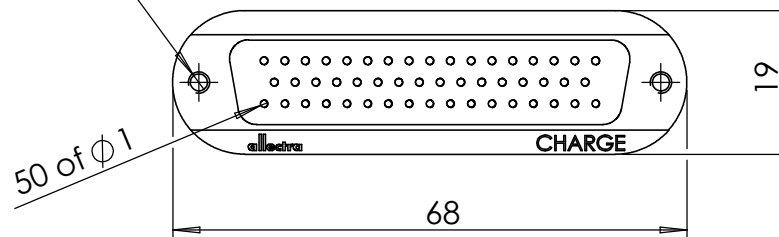

DETAIL A  
View 2 : 1

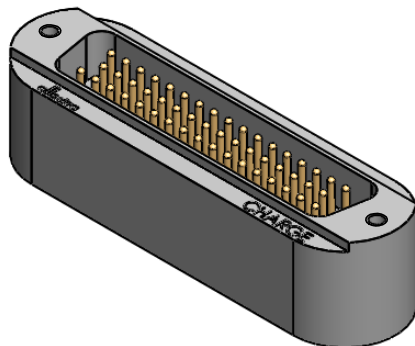
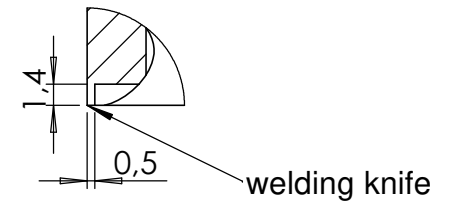

Bemerkungen (Remarks)				Freimaßtoleranz (Standard Toleranz)		Maßstab (Scale)	Rauheit (Roughness) $\sqrt{Rz\ 16\ (Rz\ 6.3)}$	europ.Projektion 		
<p>All informations provided in this drawing is considered to be confidential, proprietary and secret information. If is intended only for the use of individual or entity to whom it is sent. Individual or entity agrees to not disseminate or copy this information to anyone other than originally specified without the written consent Allectra GmbH.</p>				Datum	Name	Material, Standard Oberfläche (Treatment) <b>Stainless Steel</b>	Kanten (edges) $\pm 0,1$ $\pm 0,25$			
				Design	17.06.2013		JB	Bezeichnung (Title) <b>50 pin SUB-D f/t</b>  <b>weldable</b>	Gewicht (weight) <b>g</b> <b>89.40</b>	
				Drawn	24.09.2018		FW		Page:	Pages:
				Check					<b>1</b>	<b>1</b>
						Zeichnungsnummer (Drawing No.) <b>218-D50-SS</b>		Revision		
Index	Modification	Datum	Name			Datei (File) C:\PDMStore\C\PDMStore\		Format <b>A4</b>		