

DETAIL D  
MAßSTAB 2 : 1

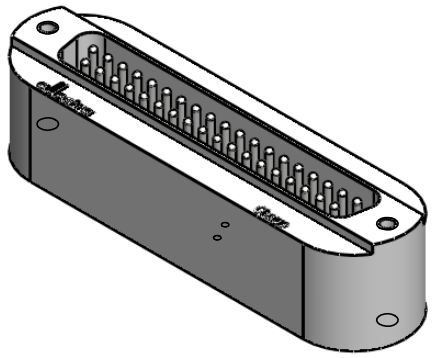
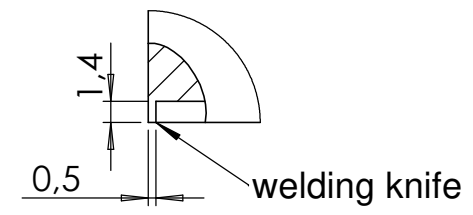

Bemerkungen (Remarks)				Freimaßtoleranz (Standard Toleranz)		Maßstab (Scale)	Rauheit (Roughness)	europ.Projektion		
All informations provided in this drawing is considered to be confidential, proprietary and secret information. If is intended only for the use of individual or entity to whom it is sent. Individual or entity agrees to not disseminate or copy this information to anyone other than originally specified without the written consent Allectra GmbH.						1:1	$\sqrt{Rz\ 16\ (Rz\ 6.3)}$			
				Datum		Name	Material, Standard	Titanium	Kanten (edges)	
				Design	26.03.2015	FW	Oberfläche (Treatment)		$\pm 0,1$	$\pm 0,25$
Drawn		11.06.2019	AD	Bezeichnung (Title)		37 pin SUB-D F/T TI		Gewicht (weight)		
Check				weldable		13.20		Page:	Pages:	
				Zeichnungsnummer (Drawing No.)		218-D37-TI		Revision		
Index	Modification	Datum	Name			Datei (File)		Format		
						C:\PDMStore\C:\PDMStore\		A4		