

POS-NR.	DESCRIPTION	Material	QTY
1	modified flange DN63 ISO-K	1.4301 (304)	1
2	50 pin SUB-D F/T	Stainless Steel	1

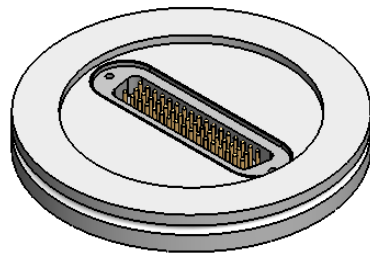
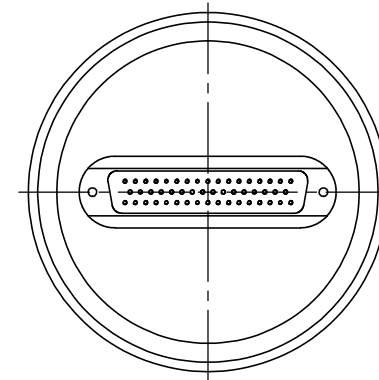
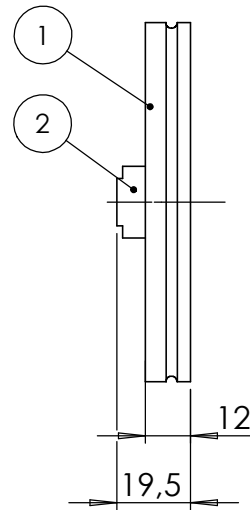
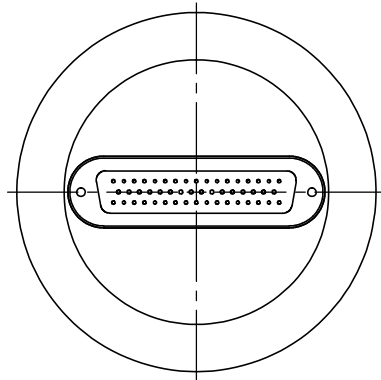

Bemerkungen (Remarks)				Freimaßtoleranz (Standard Toleranz)		Maßstab (Scale)	Rauheit (Roughness)	europ.Projektion
HSG-UHV=66 All informations provided in this drawing is considered to be confidential, proprietary and secret information. If is intended only for the use of individual or entity to whom it is sent. Individual or entity agrees to not disseminate or copy this information to anyone other than originally specified without the written consent Alletra GmbH.						1:2		
				Datum		Name	Material, Standard Oberfläche (Treatment)	Kanten (edges)
				Design	21.03.2016	JB	Bezeichnung (Title) 1 of 50 pin Sub-D f/t on flange DN63 ISO-K	Gewicht (weight) g 691.31
				Drawn	21.03.2016	JB		Page: 1 Pages: 1
				Check				Revision
							Zeichnungsnummer (Drawing No.) 210-D50-ISO63	
Index	Modification	Datum	Name				Datei (File) C:\PDMStore\IC\PDMStore\	Format A4