

POS-NR.	DESCRIPTION	MATERIAL	QTY
1	modified flange 3x 15 pin SUB-D	1.4404 (X2CrNiMo17-12-2)	1
2	15 pin SUB-D F/T weldable type	Stainless Steel	3

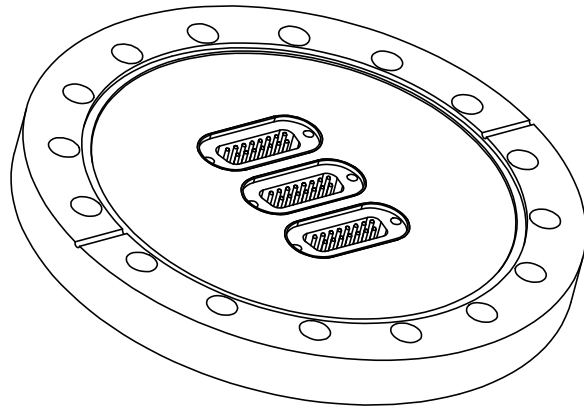

Bemerkungen (Remarks)				HSG=100						Rauheit (Roughness)		europ.Projektion			
All informations provided in this drawing is considered to be confidential, proprietary and secret information. It is intended only for the use of individual or entity to whom it is sent. Individual or entity agrees to not disseminate or copy this information to anyone other than originally specified without the written consent Allectra GmbH.				Freimaßtoleranz (Standard Toleranz)		Maßstab (Scale)									
						1:2									
				Datum		Name		Material, Standard Oberfläche (Treatment)		Kanten (edges)		Gewicht (weight) g			
				Design		11.06.2013		JB		3 of 15 pin Sub-D F/T onto flange DN100 CF		1926.70			
				Drawn		27.01.2015		JB				Page: 1		Pages: 1	
				Check											
										Zeichnungsnummer (Drawing No.)		Revision			
										210-D15-C100-3					
Index				Modification		Datum		Name		Datei (File)		Format A4			
										C:\PDMStore\IC\PDMStore\					

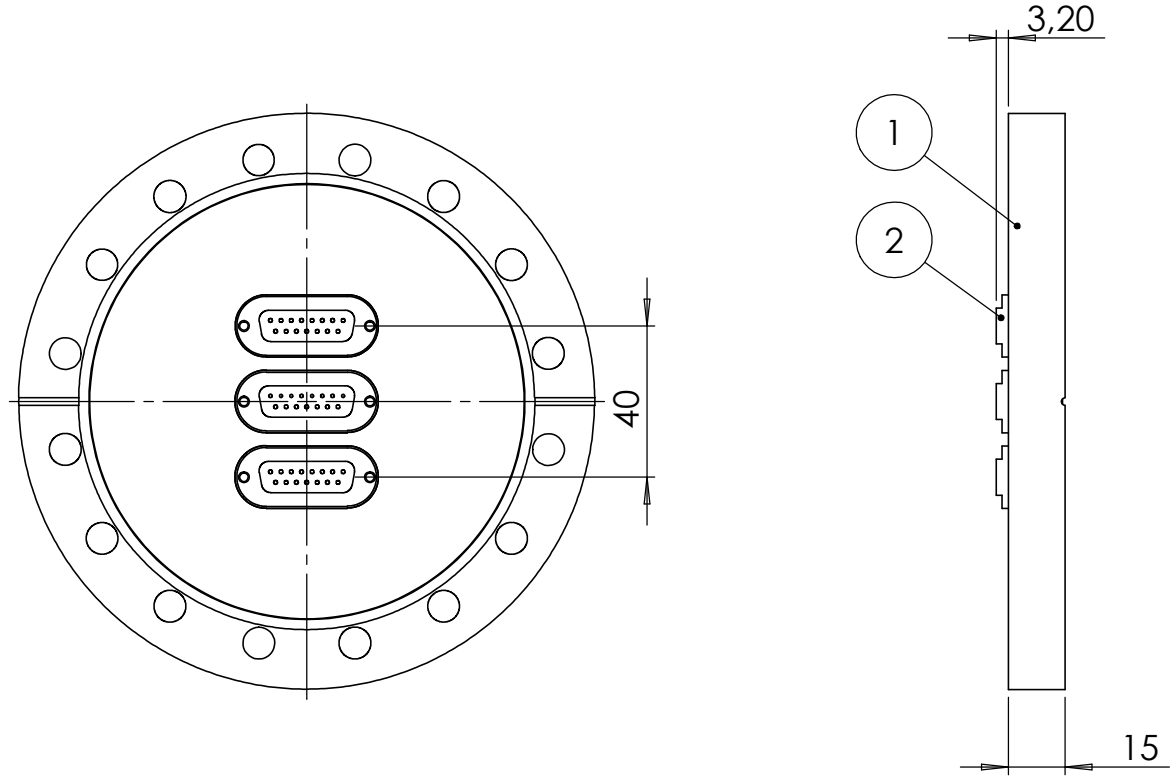