

POS-NR.	DESCRIPTION	MATERIAL	QTY
1	Modified Flange DN100 ISO K	1.4301 (X5CrNi18-10)	1
2	SUB-D 9 pin F/T	Stainless Steel	8

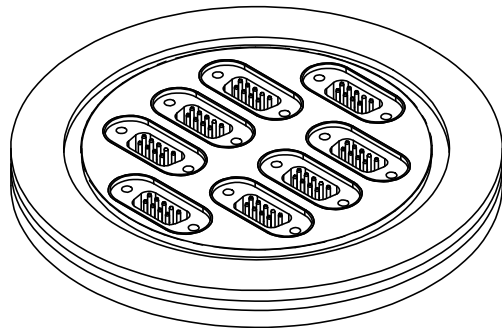
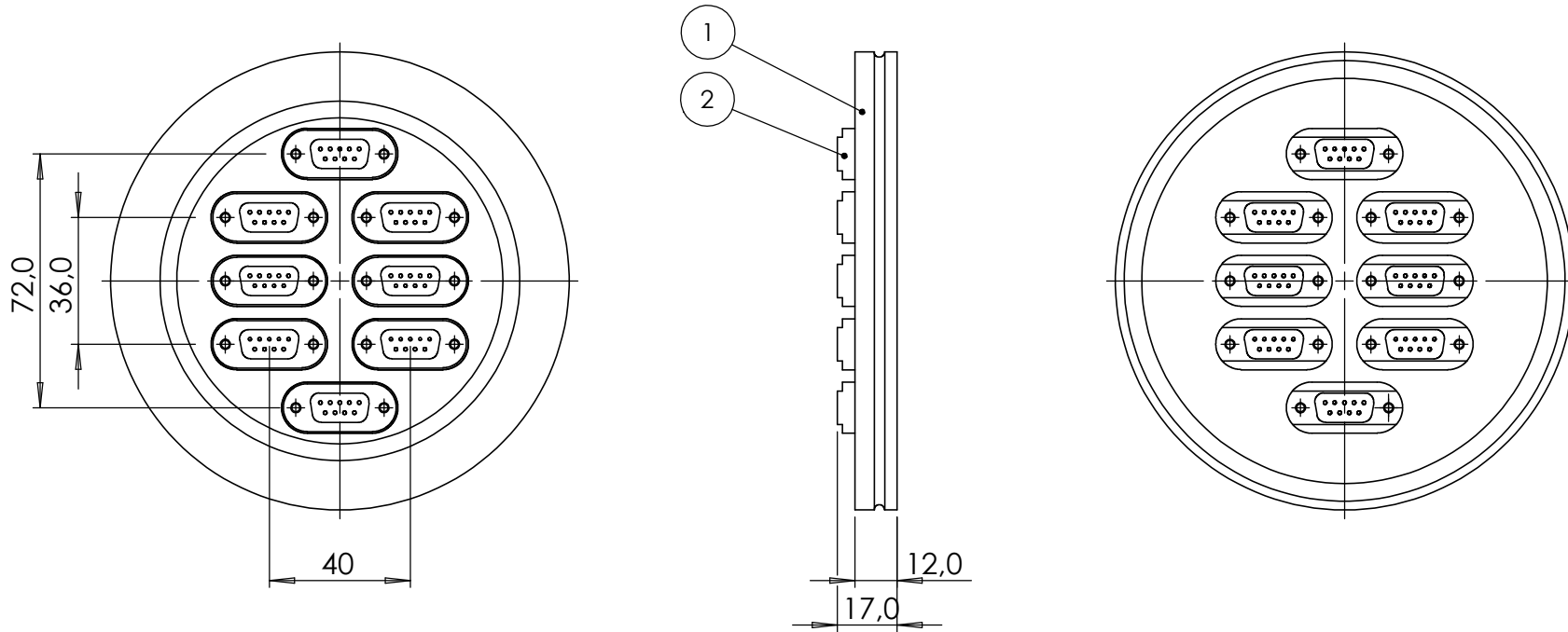

Bemerkungen (Remarks)				Freimaßtoleranz (Standard Toleranz)		Maßstab (Scale)		Rauheit (Roughness)		europ.Projektion	
HSG=100						1:2					
All informations provided in this drawing is considered to be confidential, proprietary and secret information. It is intended only for the use of individual or entity to whom it is sent. Individual or entity agrees to not disseminate or copy this information to anyone other than originally specified without the written consent Allectra GmbH.				Datum		Name		Material, Standard Oberfläche (Treatment)		Kanten (edges)	
				Design	17.12.2014	JB		Bezeichnung (Title) <b>9 pin SUB-D F/T</b> <b>onto flange DN100-ISO-K</b>			
				Drawn	17.12.2014	JB				Gewicht (weight) <b>g</b>	
				Check						1175.45	
								Zeichnungsnummer (Drawing No.)		Page: 1 Pages: 1	
								<b>210-D09-ISO100-8</b>		Revision	
Index	Modification	Datum	Name					Datei (File) c:\PDMStore\IC\PDMStore\		Format <b>A4</b>	