

POS-NR.	DESCRIPTION	MATERIAL	QTY
1	modified flange DN100 ISO-K	1.4301 (304)	1
2	optical coupler f/t FCF	1.4404 (316L)	3

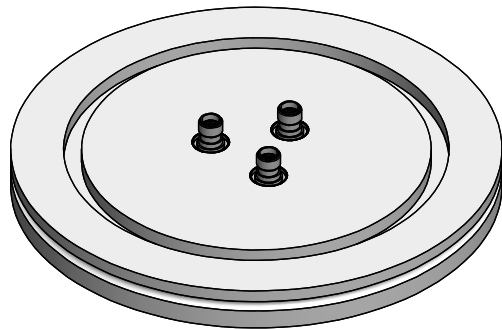
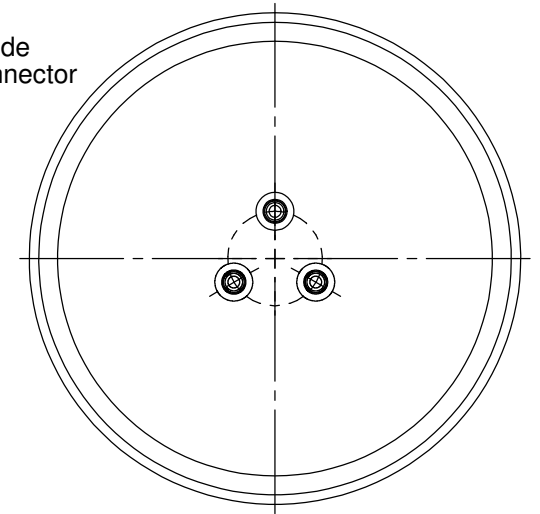
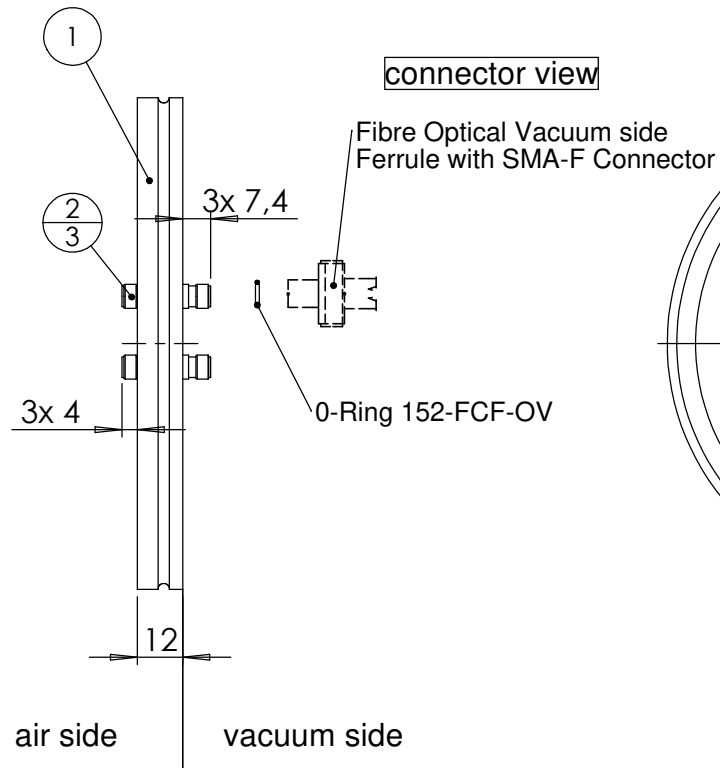
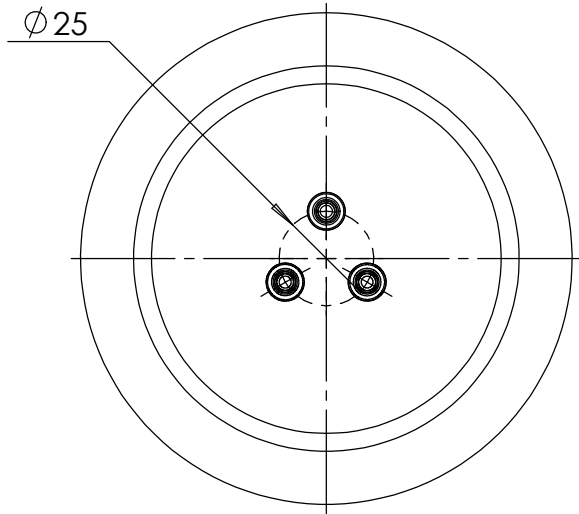

Bemerkungen (Remarks)				Freimaßtoleranz (Standard Toleranz)		Maßstab (Scale)	Rauheit (Roughness)	europ.Projektion	
All informations provided in this drawing is considered to be confidential, proprietary and secret information. If is intended only for the use of individual or entity to whom it is sent. Individual or entity agrees to not disseminate or copy this information to anyone other than originally specified without the written consent Alletra GmbH.				Datum		Name			
				Design	10.03.2021	AD	Bezeichnung (Title)		
				Drawn	10.03.2021	AD	<b>3 off optical coupler f/t FCF</b> <b>on flange DN100 ISO-K</b>		
				Check			Gewicht (weight) <b>g</b>		
							1165.44		
							Page:	Pages:	
							1	1	
							Revision		
							Zeichnungsnummer (Drawing No.) <b>152-FCF-ISO100-3</b>		
Index				Modification	Datum	Name	Datei (File) C:\PDM-Store\C:\PDM-Store\		
							Format <b>A4</b>		