

FLANGE	VCR	AIR	VACUUM	ITEM NO.
C40	1/4"	female	female	460-VCR-FF-635-C40
		female	male	460-VCR-FM-635-C40
		male	male	460-VCR-MM-635-C40
		male	female	460-VCR-MF-635-C40
	1/2"	female	female	460-VCR-FF-1270-C40
		female	male	460-VCR-FM-1270-C40
		male	male	460-VCR-MM-1270-C40
		male	female	460-VCR-MF-1270-C40
C63	1/4"	female	female	460-VCR-FF-635-C63
		female	male	460-VCR-FM-635-C63
		male	male	460-VCR-MM-635-C63
		male	female	460-VCR-MF-635-C63
	1/2"	female	female	460-VCR-FF-1270-C63
		female	male	460-VCR-FM-1270-C63
		male	male	460-VCR-MM-1270-C63
		male	female	460-VCR-MF-1270-C63

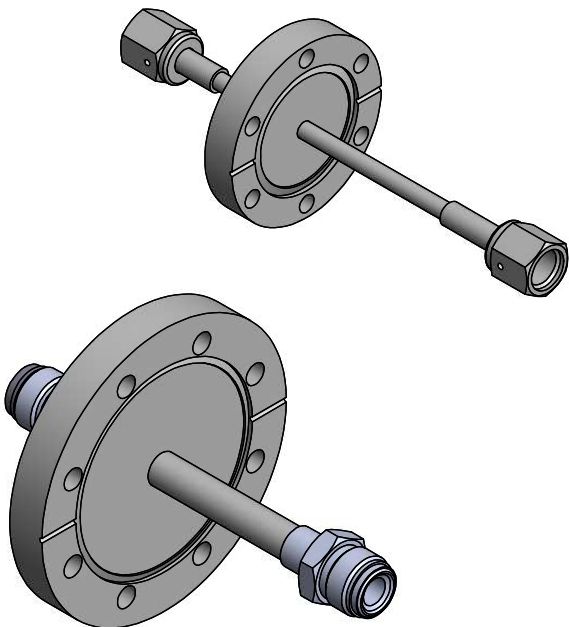

Bemerkungen (Remarks)				Freimaßtoleranz (Standard Tolerance)		Maßstab (Scale)		Rauheit (Roughness)		europ.Projektion	
All informations provided in this drawing is considered to be confidential, proprietary and secret information. If it is intended only for the use of individual or entity to whom it is sent. Individual or entity agrees to not disseminate or copy this information to anyone other than originally specified without the written consent Allectra GmbH.				1:2.5		Material, Standard Oberfläche (Treatment)		Kanten (edges)		Gewicht (weight) 9	
				Design		15.11.2022		AD		1 off VCR 1/4", 1/2"	
				Drawn		21.11.2022		AD			
				Check							
										Page: 1 Pages: 1	
										Revision	
Index				Modification		Date		Name		Format A4	

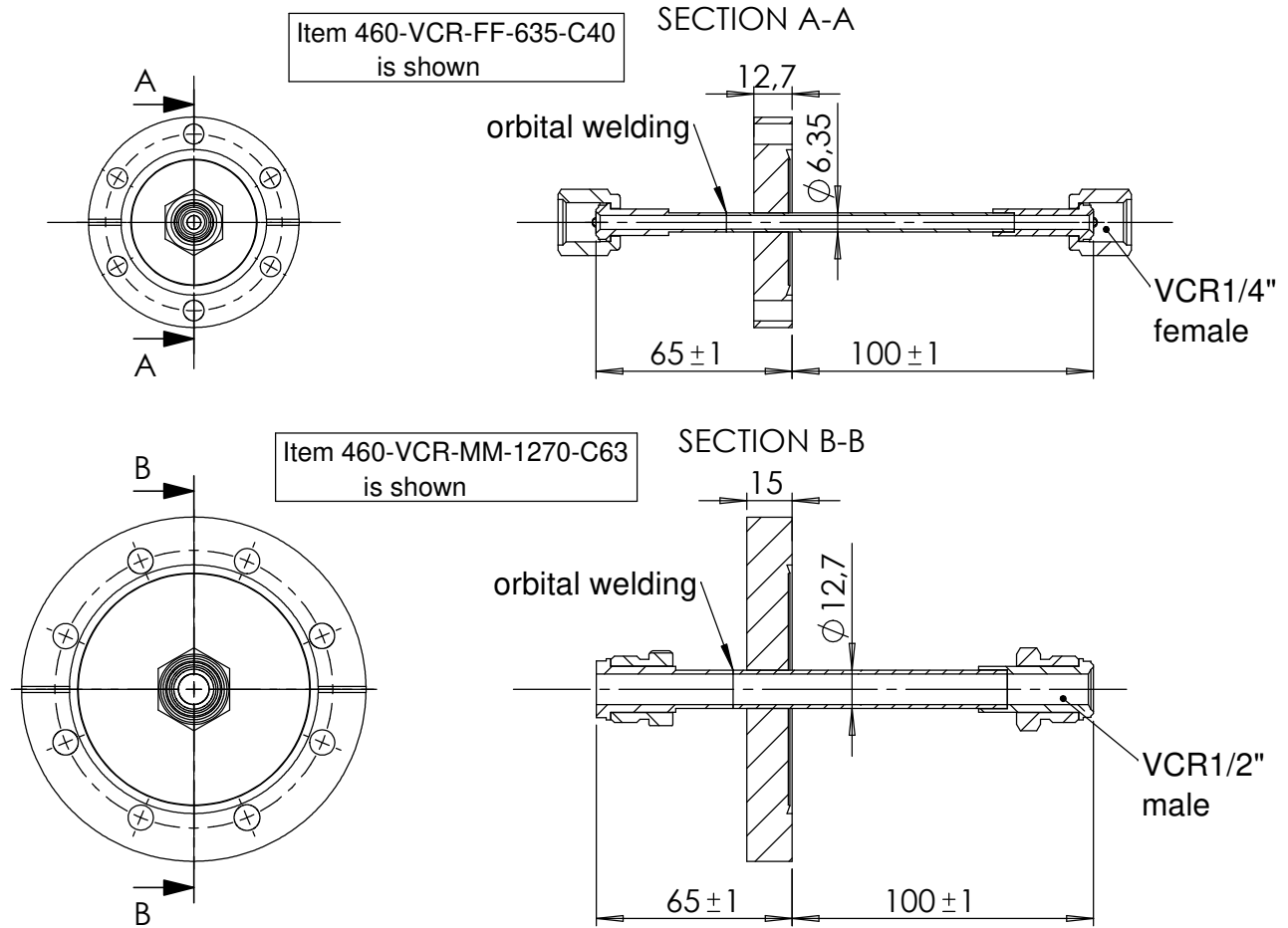

Zeichnungsnummer (Drawing No.) 460-VCR-XX-X-CX

Datei (File) C:\PDMstore\C:\PDMstore\