

POS-NR.	DESCRIPTION	MATERIAL	QTY
1	modified flange DN63 ISO-K	1.4301 (304)	1
2	SMA high frequency 27GHz, 50 OHM, welded	stainless steel	4

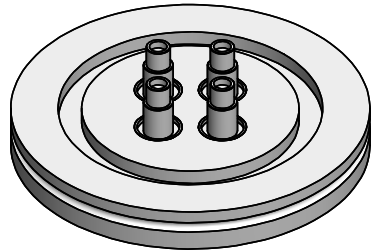
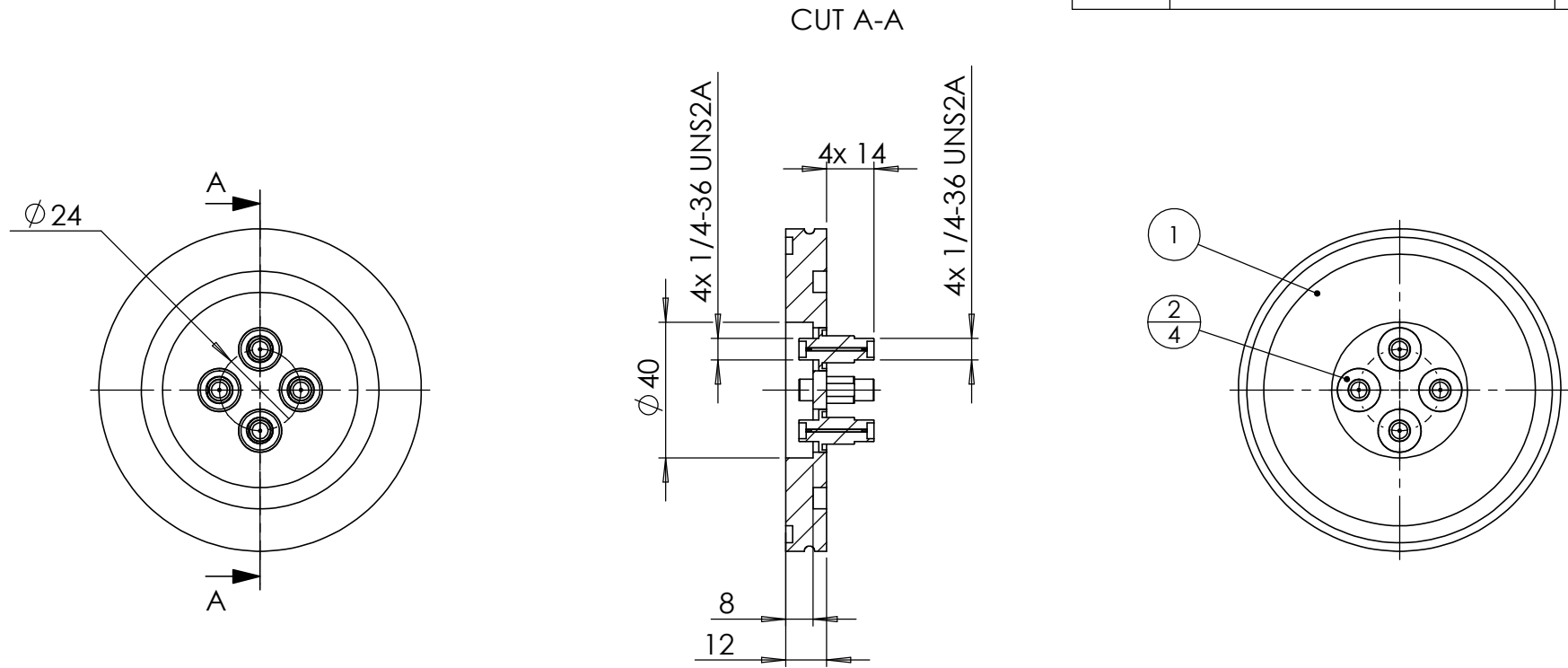

Bemerkungen (Remarks)				Freimaßtoleranz (Standard Toleranz)		Maßstab (Scale)	Rauheit (Roughness)	europ.Projektion	
All informations provided in this drawing is considered to be confidential, proprietary and secret information. It is intended only for the use of individual or entity to whom it is sent. Individual or entity agrees to not disseminate or copy this information to anyone other than originally specified without the written consent Allectra GmbH.				Datum		Name	Material, Standard Oberfläche (Treatment)	Kanten (edges)	
									Gewicht (weight) 9
Design				27.04.2020	AD	Bezeichnung (Title) 4 off SMAD27G f/t, welded on flange DN63 ISO-K	Page: 1 Pages: 1		
Drawn				27.04.2020	AD		Zeichnungsnummer (Drawing No.) 242S-SMAD27G_4-ISO63	Revision	
Check								Format A4	
Index	Modification	Datum	Name				Datei (File) C:\PDM-Store\I\C\I-PDM-Store\		