

POS. NO.	DESCRIPTION	MATERIAL	QTY
1	modified flange DN40 CF	1.4404 (316L)	1
2	SMP feedthrough, double sided, limited detent	1.4306 (304L)	8

SECTION A-A

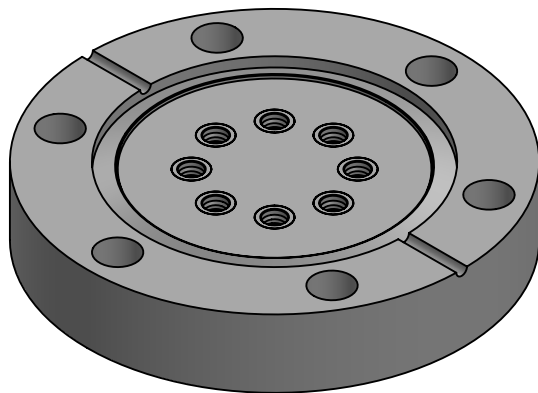
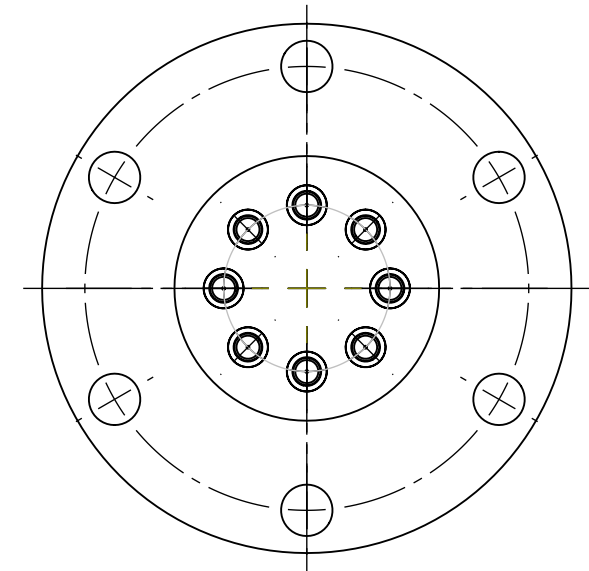
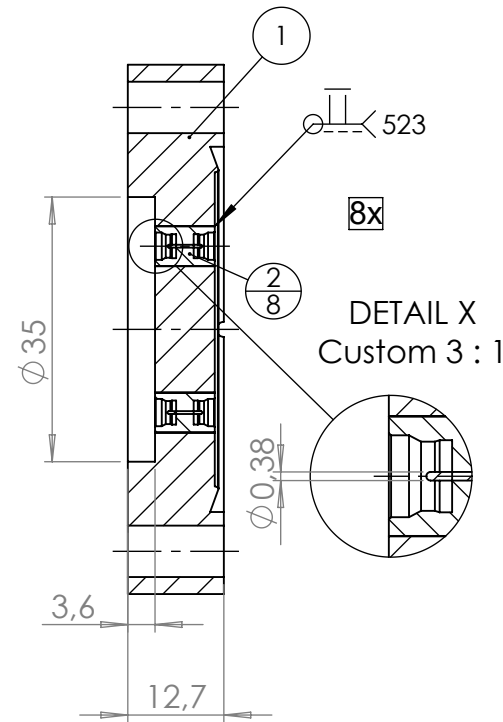
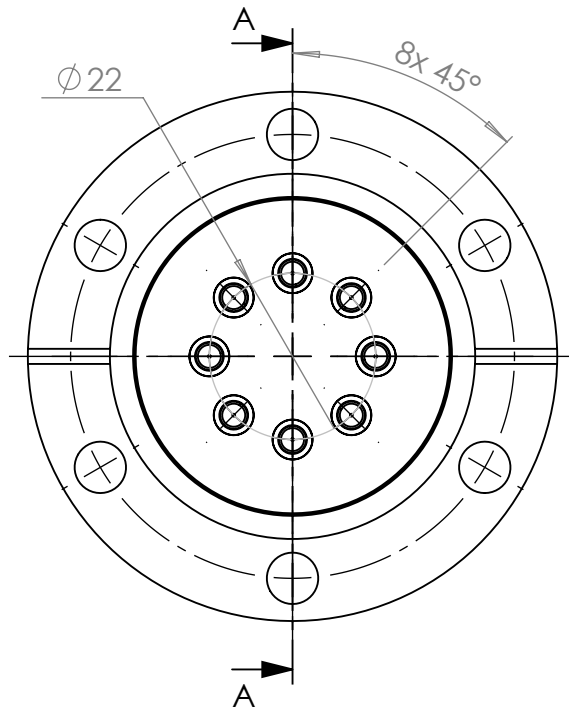

<1 E-10 mbar*/sec, He, according to DIN EN 1779-A3
Definition Leckprüfung (definon leak check)

Zeichnung Nutzung (SCOPE OF DRAWING) Drawing external usage for customer		Prüfung Zubehör. (CON + HSG CHECK)		Bemerkung (REMARKS)		Kanten (EDGES)		PROJECTION	
All informations provided in this drawing is considered to be confidential, proprietary and secret information. It is intended only for the use of individual or entity to whom it is sent. Individual or entity agrees to not disseminate or copy this information to anyone other than originally specified without the written consent Allectra GmbH.		Werkstoff (MATERIAL):		Gewicht (WEIGHT):		Toleranz (TOLERANCE):		DIN EN ISO 13920-C (welding ASSY)	
		Oberfläche (SURFACE):		Cleaned UHV- Compatible		Maßstab (SCALE):		1:1	
name: Allectra standard		DATE		NAME		PAGE NO		PAGES	
(drw/doc/sketch)		Design: 26.08.2024		AD		1		1	
date		Drawn: 12.09.2024		AD		Rauheit (ROUGHNESS)		√	
00 first origin		Check: 17.09.2024		JB		Benennung (DESCRIPTION): 8 off SMPD f/t, double sided, limited detent on flange DN40 CF			
		Approv: 17.09.2024		AD					
REV Beschreibung (CHANGING)		gesp. am (SAVE DAT.): 17.09.2024		Art. Nr. (PART NO.): 242-SMPD-LD-C40-8		Zeich. Nr. (Drw. No.): 242-SMPD-LD-C40-8		REV 00	