

POS-NR.	DESCRIPTION	MATERIAL	QTY
1	modified flange DN16 CF	1.4404 (316L)	1
2	coaxial f/t type SMA, 27GHz, 50 OHM, double sided, weldable	stainless steel	1

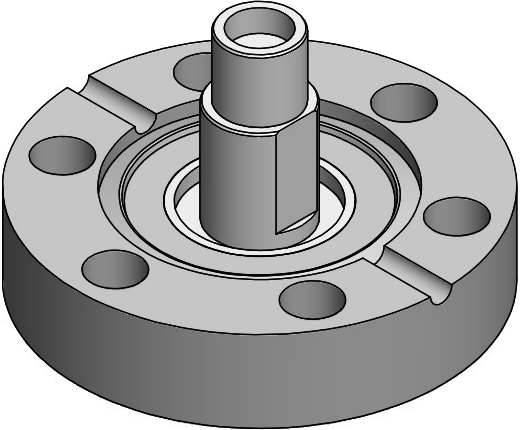
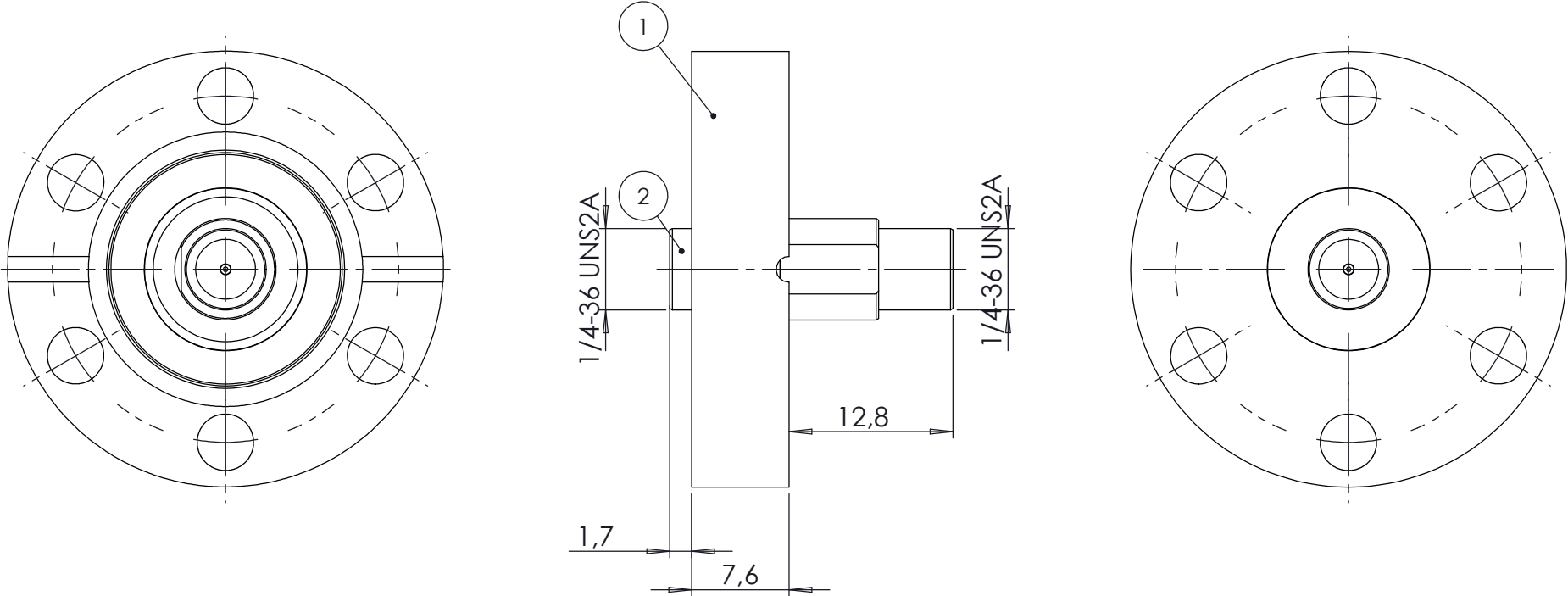

Bemerkungen (Remarks)				Freimaßtoleranz (Standard Tolerance)		Maßstab (Scale)	Rauheit (Roughness)	europ. Projektion	
All informations provided in this drawing is considered to be confidential, proprietary and secret information. It is intended only for the use of individual or entity to whom it is sent. Individual or entity agrees to not disseminate or copy this information to anyone other than originally specified without the written consent Allectra GmbH.				Datum		Name	Material, Standard Oberfläche (Treatment)		
				Drawn 09.12.2021 AD			Bezeichnung (Title)		Gewicht (weight) g
							Page: 1		Pages: 1
									Zeichnungsnummer (Drawing No.)
		242-SMAD27G-C16							
Index				Modification		Date		Name	
						Datei (File)		C:\PDM2017\C:\PDM2017\	
								Format A4	