

POS-NR.	DESCRIPTION	MATERIAL	QTY
1	modified flange DN63 CF	1.4404 (316L)	1
2	SMA high frequency 18GHz, 50 Ohm	SS-Gold Plated	9

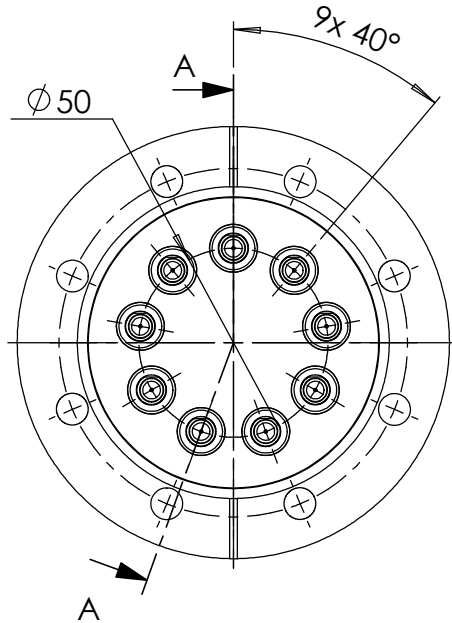

SECTION A-A

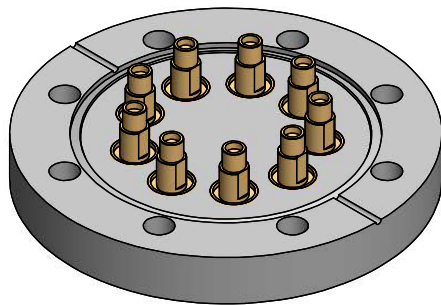
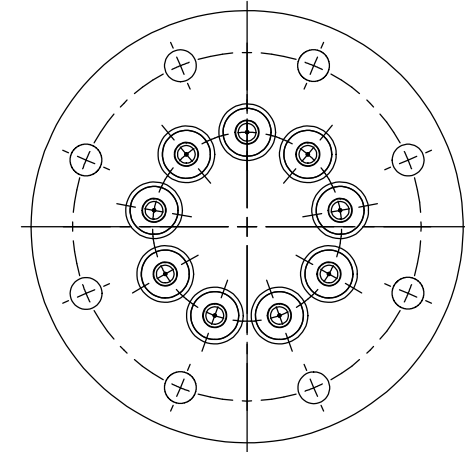
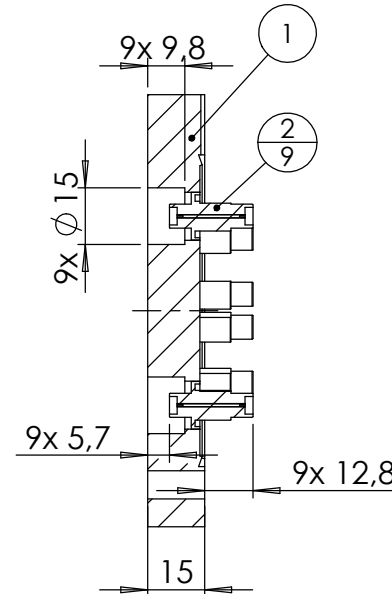

Bemerkungen (Remarks)				Freimaßtoleranz (Standard Tolerance)		Maßstab (Scale)	Rauheit (Roughness)	europ.Projektion
All informations provided in this drawing is considered to be confidential, proprietary and secret information. If is intended only for the use of individual or entity to whom it is sent. Individual or entity agrees to not disseminate or copy this information to anyone other than originally specified without the written consent Allectra GmbH.				Datum		Name	Material, Standard Oberfläche (Treatment)	Kanten (edges)
Design				15.11.2022	AD	9 off SMAD18G on flange DN63 CF	1	1
Drawn				15.11.2022	AD			
Check								
Index				Modification	Date	Name	Zeichnungsnummer (Drawing No.) 242-SMAD18G-C63-9	
						Datei (File) C:\PDMstore\C:\PDMstore\		Revision
								Format A4