

POS-NR.	DESCRIPTION	MATERIAL	QTY
1	Modified flange DN40 CF	1.4404	1
2	SMA High Frequency 18GHz, 50 Ohm	SS-Gold Plated	3

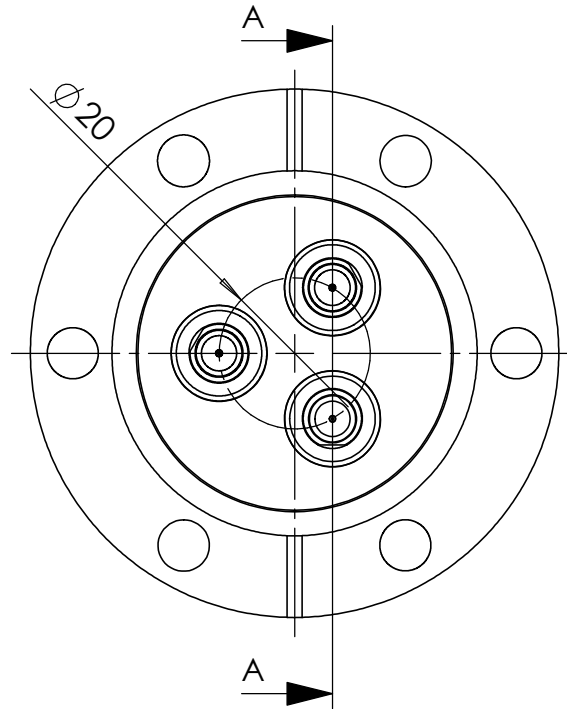

SCHNITT A-A

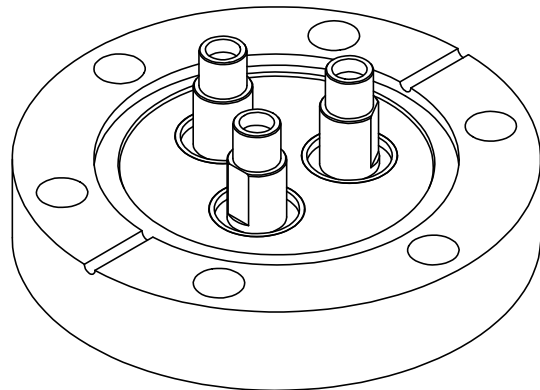
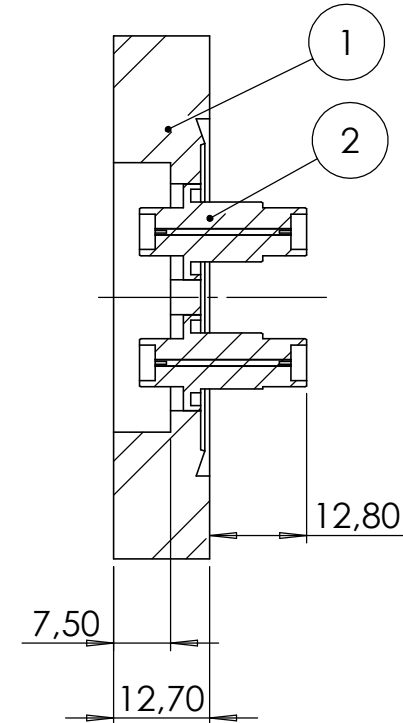

Bemerkungen (Remarks)				Freimaßtoleranz (Standard Toleranz)		Maßstab (Scale)	Rauheit (Roughness)	europ. Projektion			
All informations provided in this drawing is considered to be confidential, proprietary and secret information. If is intended only for the use of individual or entity to whom it is sent. Individual or entity agrees to not disseminate or copy this information to anyone other than originally specified without the written consent Allelectra GmbH.						1:1					
								Material, Standard Oberfläche (Treatment)		Kanten (edges)	
				Design	12.11.2014	JB	Bezeichnung (Title) 3 of SMAD18G on flange DN40 CF		Gewicht (weight) g		
				Drawn	12.11.2014	JB			294.89		
				Check					Page: 1 Pages: 1		
								Revision		00	
Index				Modification		Datum		Name		Format A4	
										Zeichnungsnummer (Drawing No.) 242-SMAD18G-C40-3	
								Datei (File) C:\PDMStore\C\PDMStore\			