

POS-NR.	DESCRIPTION	MATERIAL	QTY
1	modified flange DN63 ISO-K	1.4301 (304)	1
2	coaxial f/t type SHV, 50 Ohm, 6KV, 3A, double sided, grounded shield, weldable	Stainless Steel	4

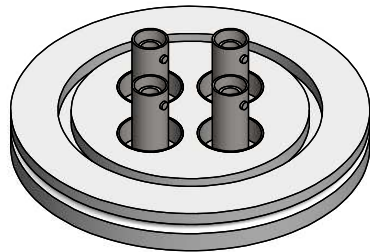

Bemerkungen (Remarks)				Freimaßtoleranz (Standard Tolerance)		Maßstab (Scale)		Rauheit (Roughness)		europ.Projektion	
All informations provided in this drawing is considered to be confidential, proprietary and secret information. It is intended only for the use of individual or entity to whom it is sent. Individual or entity agrees to not disseminate or copy this information to anyone other than originally specified without the written consent Alletra GmbH.				Datum		Name		Material, Standard Oberfläche (Treatment)		Kanten (edges)	
Design				08.06.2022		AD		Bezeichnung (Title) 4 off coaxial f/t type SHV, double sided, 50 Ohm on flange DN63 ISO-K		Page:	
Drawn				08.06.2022		AD				1	
Check										Pages:	
										Revision	
Index				Modification		Date		Name		Format A4	

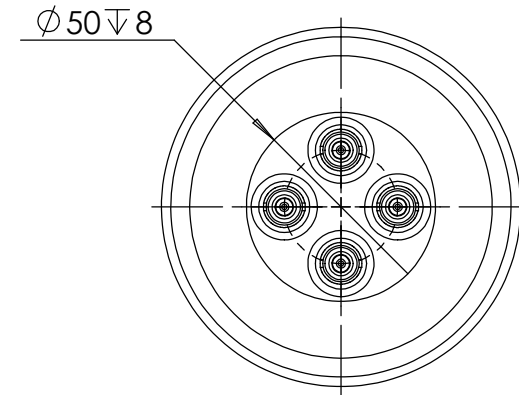
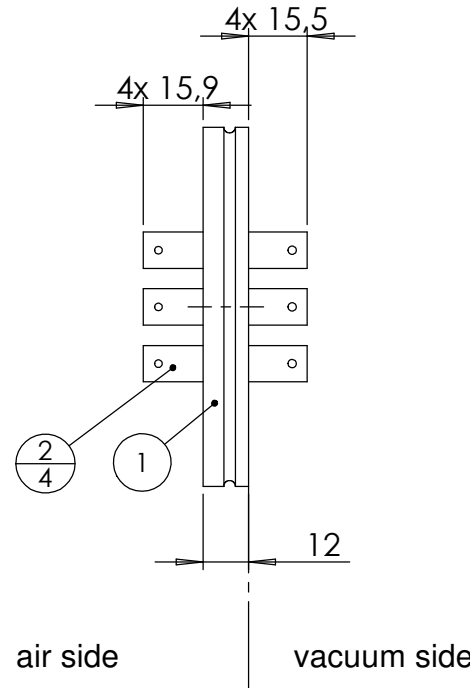
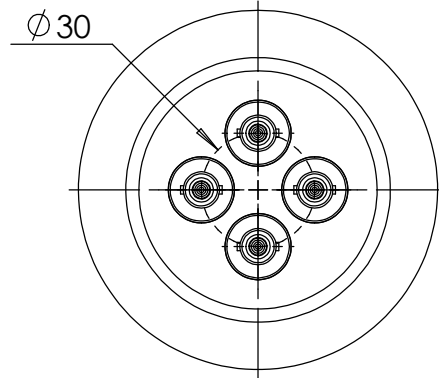

Zeichnungsnummer (Drawing No.)
242-SHVD50-ISO63-4

Datei (File) C:\PDM-Store\I:\PDM-Store\