

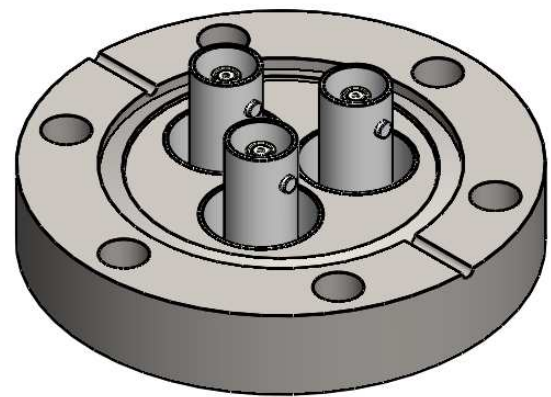

POS-NR.	DESCRIPTION	MATERIAL	QTY
1	modified flange DN40 CF	1.4404	1
2	MHV f/t, double sided, floating shield, 50 ohm, 5KV, 3A weldable	Stainless Steel	3

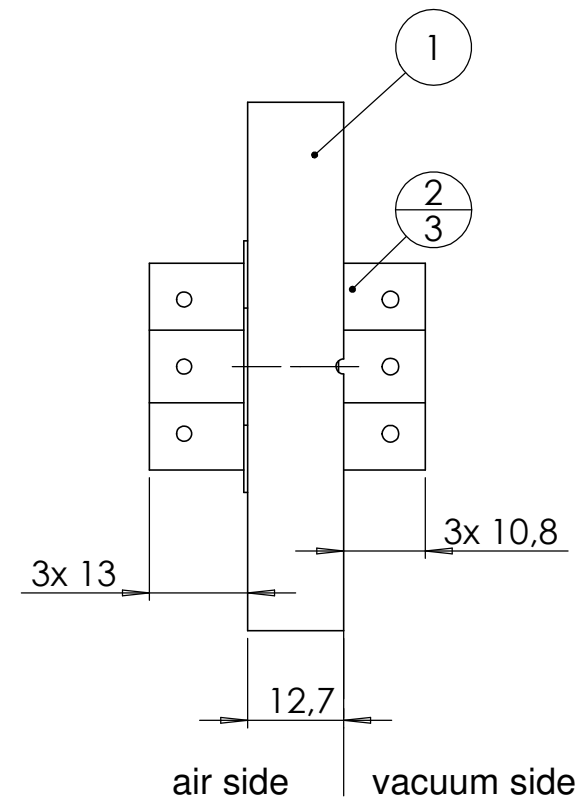
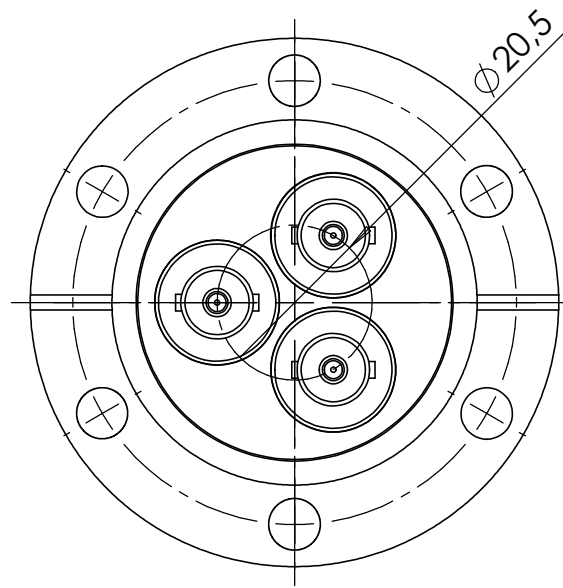

Bemerkungen (Remarks)				Freimaßtoleranz (Standard Toleranz)		Maßstab (Scale)	Rauheit (Roughness)	europ.Projektion	
All informations provided in this drawing is considered to be confidential, proprietary and secret information. If is intended only for the use of individual or entity to whom it is sent. Individual or entity agrees to not disseminate or copy this information to anyone other than originally specified without the written consent Allectra GmbH.				Datum		1:1	Material, Standard Oberfläche (Treatment)	Kanten (edges)	
				Name				Gewicht (weight) g	
Design				15.10.2020	AD	Bezeichnung (Title) 2 off MHVDF50 f/t on flange DN40 CF	1		
Drawn				15.10.2020	AD		Pages: 1 1		
Check							Revision		
							Zeichnungsnummer (Drawing No.) 242-MHVDF50-C40-3		
Index				Modification			Datei (File) C:\PDM-Store\C:\PDM-Store\		
Datum				Name		Format A4			