

POS. NO.	DESCRIPTION	MATERIAL	QTY
1	modified flange DN40 CF	1.4404 (316L)	1
2	4 pin M12x4 feedthrough	Stainless Steel	1

SECTION A-A

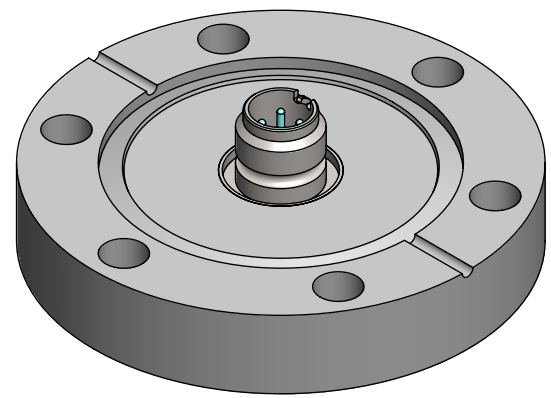
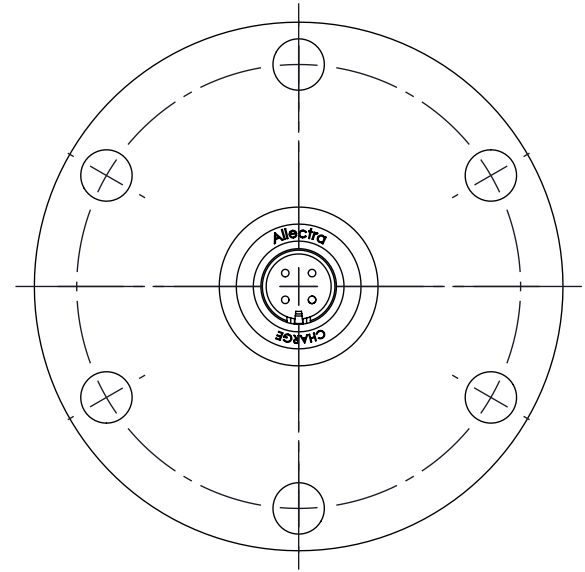
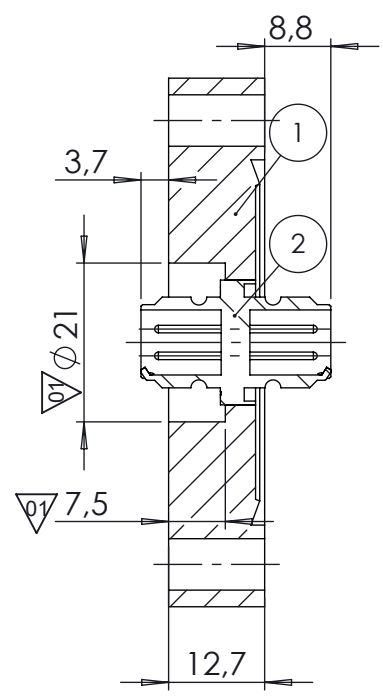
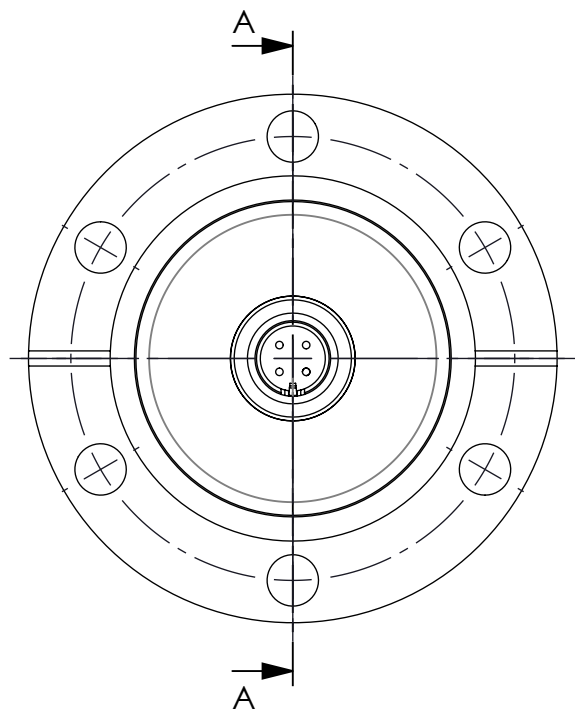

<1 E-10 mbar\*/sec, He, according to DIN EN 1779-A3  
Definition Leckprüfung (definon leak check)

Zeichnung Nutzung (SCOPE OF DRAWING) Drawing external usage for customer		Prüfung Zubehör. (CON + HSG CHECK)		Bemerkung (REMARKS)		Kanten (EDGES)		PROJECTION	
All informations provided in this drawing is considered to be confidential, proprietary and secret information. It is intended only for the use of individual or entity to whom it is sent. Individual or entity agrees to not disseminate or copy this information to anyone other than originally specified without the written consent Allectra GmbH.		Werkstoff (MATERIAL):		Gewicht (WEIGHT):		Toleranz (TOLERANCE):		DIN EN ISO 13920-C (welding ASSY)	
		Oberfläche (SURFACE):		Cleaned UHV- Compatible		Maßstab (SCALE):		1:1	
name		Allectra standard		DATE		NAME		Benennung (DESCRIPTION):	
(drw/doc/sketch)				Design		26.04.2021		AD	
date				Drawn		10.10.2024		AD	
01		counter bore dimension added		Check		14.10.2024		JB	
				Approv		14.10.2024		AD	
REV		Beschreibung (CHANGING)		gesp. am (SAVE DAT.):		14.10.2024		Art. Nr. (PART NO.) 220-M12X4-C40	
						Zeich. Nr. (Drw. No.):		220-M12X4-C40	
								REV	
								01	