

POS-NR.	DESCRIPTION	Material	QTY
1	housing-UHV 44 Pin	3.2315 (EN-AW 6082) T6	2
2	screw M2.5 x 5	Stainless Steel	2
3	strain relief for UHV	1.4301 (304)	1
4	screw M2.5 x 12	Stainless Steel	2

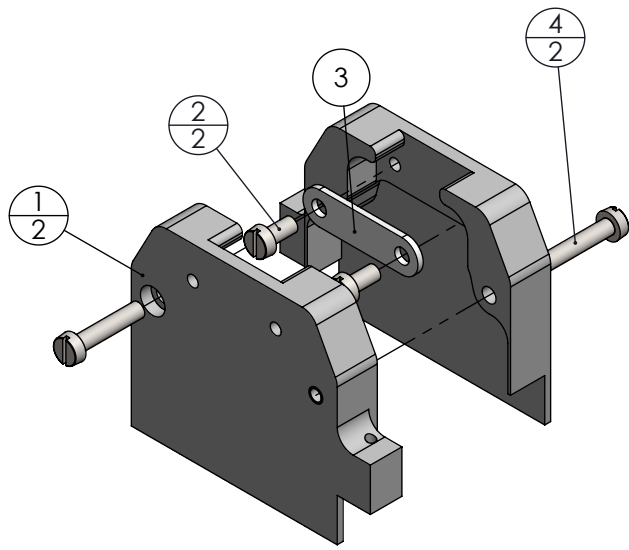
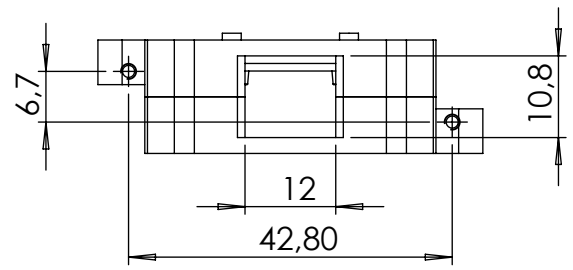
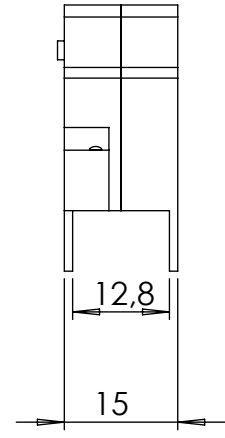
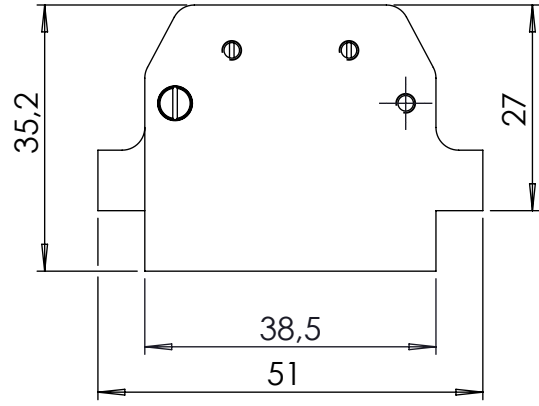

<p>All informations provided in this drawing is considered to be confidential, proprietary and secret information. It is intended only for the use of individual or entity to whom it is sent. Individual or entity agrees to not disseminate or copy this information to anyone other than originally specified without the written consent Alletra GmbH.</p>	Verwendetes Material (USED MATERIAL)		Bemerkung (REMARKS)	Kanten (EDGES)	PROJECTION	
	Toleranz (TOLERANCE)		Maßstab (SCALE): 1:1	Gewicht (WIGHT): g		
Oberfläche (SURFACE) Cleaned UHV- Compatible	Rauheit (ROUGHNESS) √		Werkstoff (MATERIAL):	Bl. (page) A4	page 1	pages 1
origin name Alletra standard	DATE	NAME	Benennung (DESCRIPTION): housing for 44 pin, UHV standard SUB-HD connector			
origin (drw/sketch/part no)	Design 24.07.2015	JB				
date of origin	Drawn 01.11.2023	JB				
	Check 02.11.2023	AD				
01	Pos.1 material changed		Approv 02.11.2023	AD		
					Zeich. Nr. (Drw. No.): 211-HSG-HD44-UHV	REV 01
REV	Beschreibung (CHANGING)	LAST SAVE DAT.: 02.11.2023			part. no. 211-HSG-HD44-UHV	