

SCHNITT A-A

POS-NR.	DESCRIPTION	MATERIAL	QTY
1	housing part SUB-D 37 pin	nickel plated	2
2	strain relief package		1
2.1	strain relief for sheet UHV	1.4301 (X5CrNi18-10)	2
2.2	Chese Head screw M2,5x10	Stainless Steel	2
2.3	Hexagon Nut M2.5	Stainless Steel	2
3	SUB-D SCREW long 4-40	steel nickel plated	2
4	housing Hexagon nut	steel nickle I plated	2
5	housing screw	steel nickel plated	2

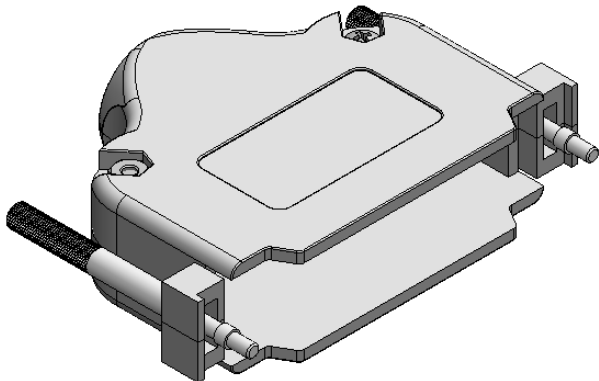

Bemerkungen (Remarks)			
All informations provided in this drawing is considered to be confidential, proprietary and secret information. It is intended only for the use of individual or entity to whom it is sent. Individual or entity agrees to not disseminate or copy this information to anyone other than originally specified without the written consent Alletra GmbH.			
Index	Modification	Datum	Name

Freimaßtoleranz (Standard Toleranz) Maßstab (Scale) 1:1	Datum Design 20.01.2017 JB Drawn 20.01.2017 JB Check	Name JB	Rauheit (Roughness) 	europ.Projektion
			Material, Standard Oberfläche (Treatment)	Kanten (edges)
Bezeichnung (Title) 37 pin SUB-D housing high vacuum varia			Gewicht (weight) g 28.06	Page: 1
Zeichnungsnummer (Drawing No.) 211-HSG-D37-SR			Pages: 1	
Datei (File) X:\PDM-Store\X:\PDM-Store\			Revision	
			Format A4	