

POS-NR.	DESCRIPTION	MATERIAL	QTY
1	housing-UHV, 25 pin	3.2315 (EN-AW 6082) T6	2
2	screw M2.5 x 5	Stainless Steel	2
3	strain relief for UHV	1.4301 (304)	1
4	screw M2.5 x 12	Stainless Steel	2

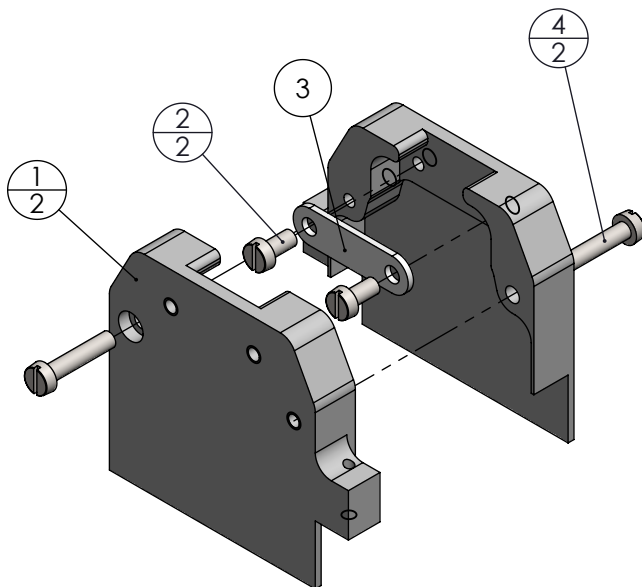

<p>All informations provided in this drawing is considered to be confidential, proprietary and secret information. It is intended only for the use of individual or entity to whom it is sent. Individual or entity agrees to not disseminate or copy this information to anyone other than originally specified without the written consent Allectra GmbH.</p>	Verwendetes Material (USED MATERIAL)		Bemerkung (REMARKS)	Kanten (EDGES)	PROJECTION
	Toleranz (TOLERANCE)		Maßstab (SCALE): 1:1	Gewicht (WIGHT):	21.969
Oberfläche (SURFACE) Cleaned UHV- Compatible	Rauheit (ROUGHNESS) √		Werkstoff (MATERIAL):	Bl. (page) A4	page 1 pages 1
origin name Allectra standard	DATE	NAME	Benennung (DESCRIPTION): housing for 25 pin, UHV standard SUB-HD connector		
origin (drw/sketch/part no)	Design 21.09.2009	JB			
date of origin	Drawn 01.11.2023	JB			
	Check 02.11.2023	AD			
01	Pos.1 material changed	Approv 02.11.2023	AD	Zeich. Nr. (Drw. No.): 211-HSG-D25-UHV	
REV	Beschreibung (CHANGING)	LAST SAVE DAT.: 02.11.2023		part. no. 211-HSG-D25-UHV	

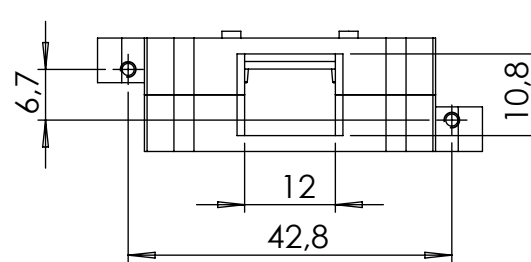
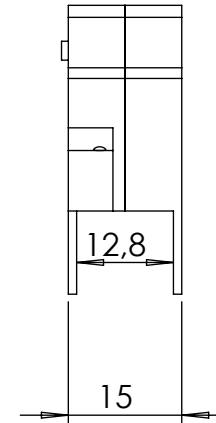
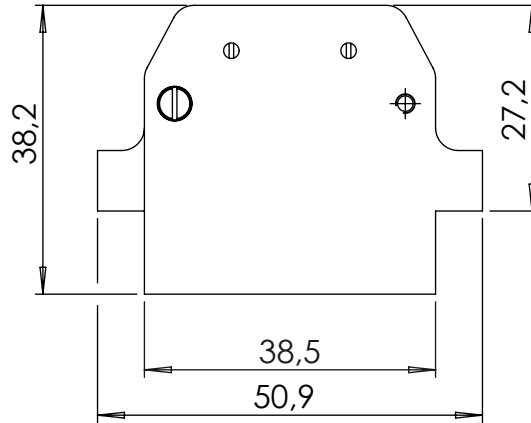

REV
01