

| POS-NR. | DESCRIPTION | MATERIAL | QTY |
|---------|---------------------------------|-----------------|-----|
| 1 | modified flange DN100 CF | 1.4404 (316L) | 1 |
| 2 | 78 pin pin SUB-High Density f/t | Stainless Steel | 2 |

SCHNITT A-A

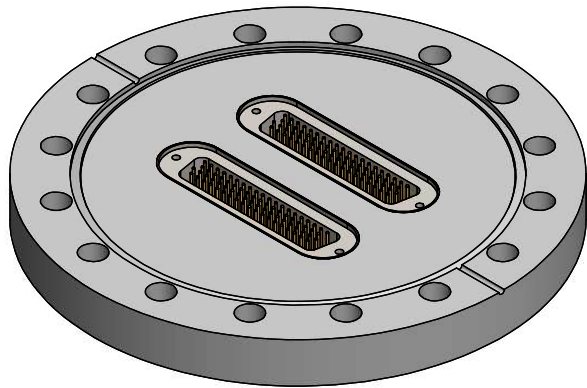
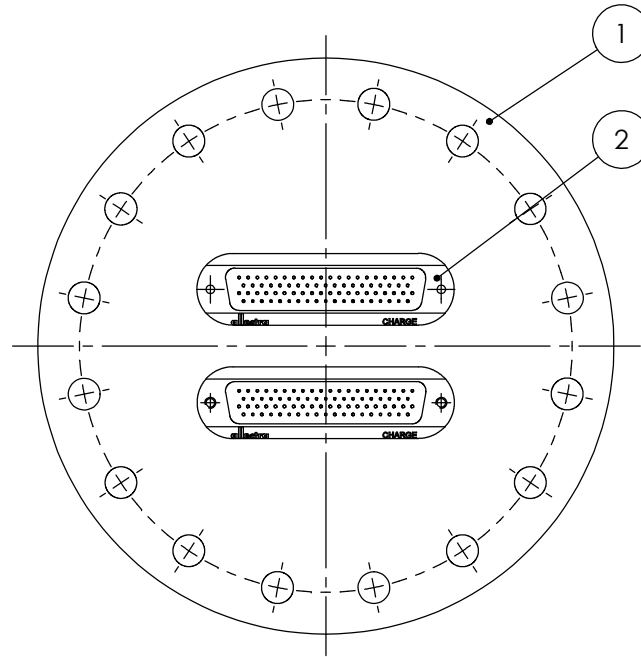
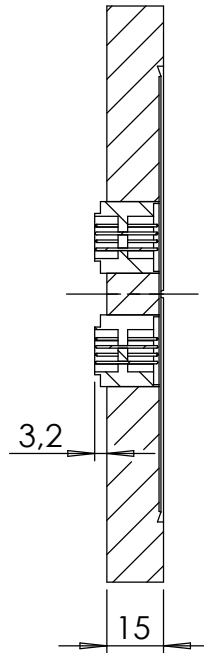
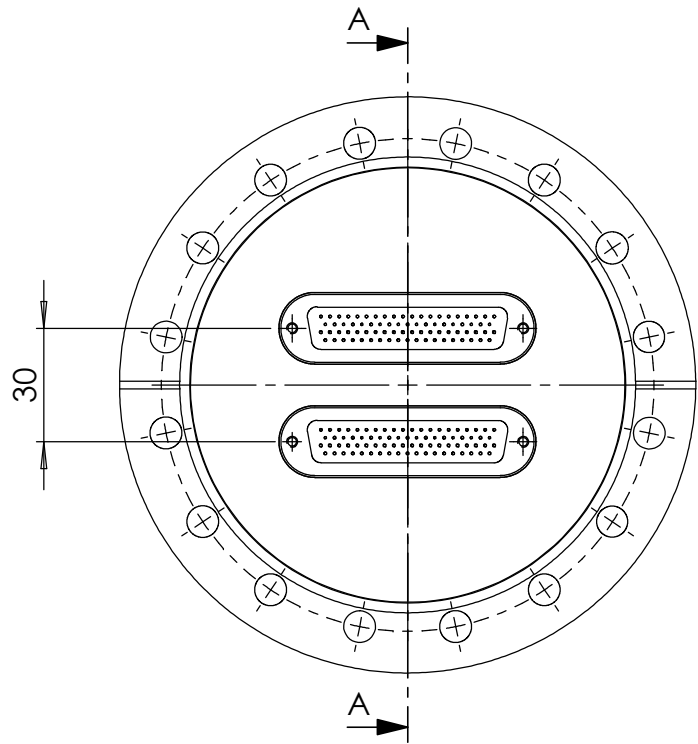

| | | | | | | | | | | |
|--|--------------|-------|------|-------------------------------------|------------|---|---------------------|----------------------------|---------|----------|
| Bemerkungen (Remarks) HSG-UHV=100 | | | | Freimaßtoleranz (Standard Toleranz) | | Maßstab (Scale) 1:2 | Rauheit (Roughness) | europ.Projektion | | |
| All informations provided in this drawing is considered to be confidential, proprietary and secret information. It is intended only for the use of individual or entity to whom it is sent. Individual or entity agrees to not disseminate or copy this information to anyone other than originally specified without the written consent Allectra GmbH. | | | | Datum | | Material, Standard Oberfläche (Treatment) | | Kanten (edges) | | |
| | | | | Name | | Bezeichnung (Title) 2x 78 pin SUB-D HD f/t on flange DN100 CF | | Gewicht (weight) 9 1881.11 | | |
| | | | | Design | 07.11.2019 | AD | | | Page: 1 | Pages: 1 |
| | | | | Drawn | 07.11.2019 | AD | | | | |
| | | | | Check | | | | | | |
| | | | | | | Zeichnungsnummer (Drawing No.) 210-HD78-C100-2 | | Revision | | |
| Index | Modification | Datum | Name | | | Datei (File) C:\PDMStore\C:\PDMStore\ | | Format A4 | | |