

POS-NR.	DESCRIPTION	Material	QTY
1	modified flange DN63 ISO-K	1.4301 (X5CrNi18-10)	1
2	37 pin SUB-D f/t	Stainless Steel	1

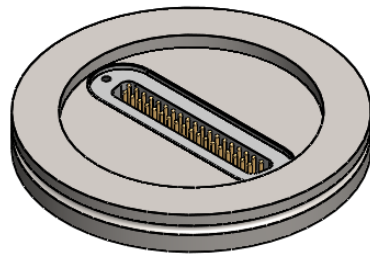
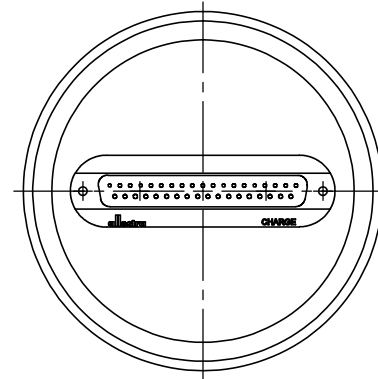
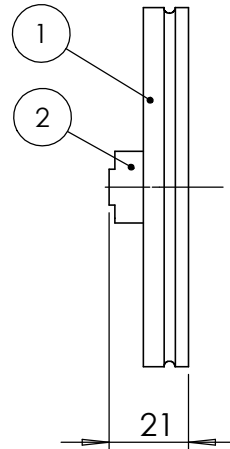
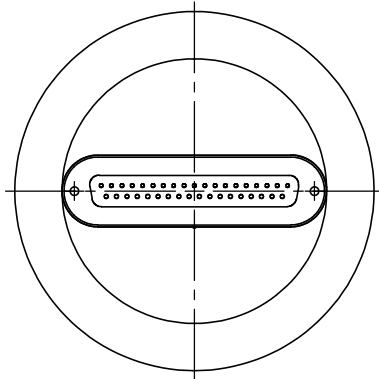

Bemerkungen (Remarks)				Freimaßtoleranz (Standard Toleranz)		Maßstab (Scale)	Rauheit (Roughness)	europ.Projektion	
HV-CON-SX						1:2			
All informations provided in this drawing is considered to be confidential, proprietary and secret information. It is intended only for the use of individual or entity to whom it is sent. Individual or entity agrees to not disseminate or copy this information to anyone other than originally specified without the written consent Allectra GmbH.							Material, Standard Oberfläche (Treatment)	Kanten (edges)	
		Datum	Name	Bezeichnung (Title)				Gewicht (weight) g	
		Design	22.05.2017	JB	1 of 37 pin Sub-D f/t				680.60
		Drawn	22.05.2017	JB	on flange DN63 ISO-K				Page: 1
		Check							Pages: 1
						Zeichnungsnummer (Drawing No.)			Revision
						210-D37-ISO63			
Index	Modification	Datum	Name			Datei (File) X:\PDM-Store\X:\PDM-Store\			Format A4